



Sun-Tek Manufacturing, Inc.
 10303 General Drive
 Orlando, FL 32824
 (407) 859-2117
 www.Sun-Tek.com
 CustomerService@sun-tek.com

INSTALLATION INSTRUCTIONS INSULATED GLASS SERIES

MODEL IFGC

Minimum 2:12 pitch required.

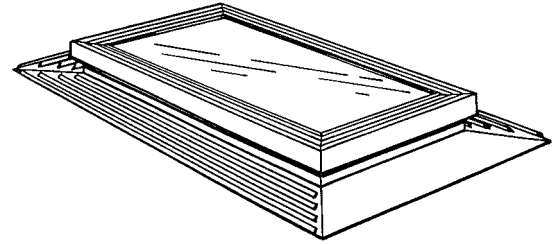

SIZE INFORMATION				Fastener Schedule	
Size Code	Roof Opening	Finished Opening (½" Drywall Dimension)	Fits on Center Spacing	#10 x 1 Phillips Pan Head Screws	
				Short Side (Per)	Long Side (Per)
1414	11½" x 11½"	10½" x 10½"	16"	3	3
1422	11½" x 19½"	10½" x 18½"	16"	3	3
1430	11½" x 27½"	10½" x 26½"	16"	3	3
1446	11½" x 43½"	10½" x 42½"	16"	3	5
1725	14½" x 22½"	13½" x 21½"	16"	3	3
1733	14½" x 30½"	13½" x 29½"	16"	3	4
1749	14½" x 46½"	13½" x 45½"	16"	3	5
2222	19½" x 19½"	18½" x 18½"	24"	3	3
2230	19½" x 27½"	18½" x 26½"	24"	3	3
2246	19½" x 43½"	18½" x 42½"	24"	3	5
2525	22½" x 22½"	21½" x 21½"	24"	3	3
2533	22½" x 30½"	21½" x 29½"	24"	3	4
2549	22½" x 46½"	21½" x 45½"	24"	3	5
3030	27½" x 27½"	26½" x 26½"	16" or 32"	3	3
3046	27½" x 43½"	26½" x 42½"	16" or 32"	3	5
3333	30½" x 30½"	29½" x 29½"	16" or 32"	4	4
3349	30½" x 46½"	29½" x 45½"	16" or 32"	4	6
4646	43½" x 43½"	42½" x 42½"	16", 24" or 48"	6	6
4949	46½" x 46½"	45½" x 45½"	16", 24" or 48"	6	6

You will need:

- hammer
- keyhole saw
- skill saw
- nails
- drill
- 2 x 4's
- sealant/mastic
- tape measure
- chalkline or straight edge
- trowel or caulk gun
- utility knife

For Light Tunnel:

- 8 or 10 penny nails
- plywood or drywall

RECOMMENDED SEALANTS:

- 100% Silicone
- STS 1000 (Sun-Tek exclusive) Butyl rubber sealant/caulk

FAILURE TO FOLLOW RECOMMENDED INSTALLATION PROCEDURES MAY VOID WARRANTY

Check local building codes for glass requirements. • Please read instructions completely before beginning. • Deck and roofing felt should already be installed. • Interior wood liner should be stained or painted before installation.

All installation information is supplied in good faith, but without recommendation to its use. No guarantee of the results of any use of this information is to be implied, since conditions of use are beyond our control. Please consult local building codes for compliance before installing.

- To properly position skylight between trusses/rafters, locate the roof opening from the underside of the decking. (If this area is not accessible, locate the ceiling joists from inside the house, mark opening in ceiling (a-c), and cut ceiling opening. Then follow steps below for roof opening.)
 - measure distance between trusses/rafters and mark center point.
 - to center skylight, measure one-half of appropriate roof opening to each side of center point and mark.
 - using the side marks as a guide, mark corners by drilling holes or driving nails through roof.
- Remove shingles 6 - 8" out from roof opening.
- Cut roof opening (snap a chalkline from corner to corner, or draw line with a straightedge.)
- Frame roof opening:
 - cut two 2 x 4's to fit the actual distance between trusses/rafters and nail into place. **NOTE: Size 2525, 2549, 3333, 3349, 4949 Skip step "b" proceed to "c".**
 - cut two 2 x 4's to the exact length of the roof opening and nail to the trusses/rafters.
 - if applicable, cut ceiling opening and build tunnel framing. (See "Light Tunnel Installation Instructions.")
- Shingle up roof to bottom of roof opening.
- Apply approved sealant in a 3" wide band around the entire opening. (Caulking: Apply 3 ⅜" beads one inch apart or 3" x ⅛" butyl tape.)
- Center skylight to cover all aluminum from inside exposure. Set skylight over opening. The label "This Edge Down" should be at the bottom of the opening. This insures proper functioning of the condensation wick. Fasten the skylight to the roof using #10 x 1" pan head screws (**see fastener schedule**). The screws should be stainless steel, galvanized or zinc plated for resistance to corrosion. Use the pre-drilled holes for the fasteners. Place a large bead of sealant at the joint between the flange and the roof deck. Also, seal the head of each fastener.

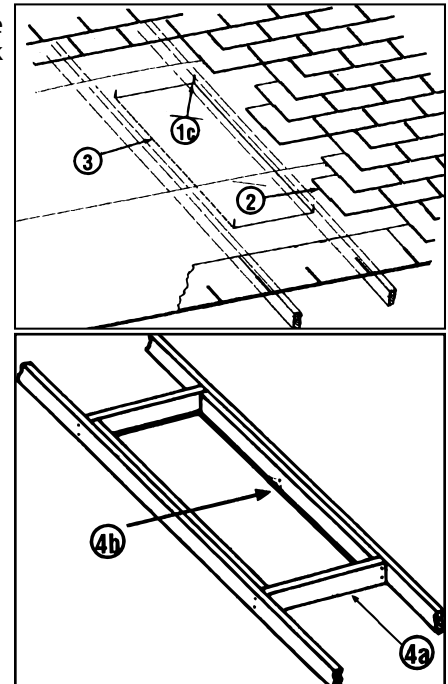

IMPORTANT: Bottom flange of skylight MUST go on top of shingles.

- 8** Now shingle up sides and across top. Place shingles, as far in as possible, but be careful not to nail through skylight flange.
- DO NOT place any sealant on the top side of the skylight flange! Sealant In this area will block the water diversion channels on the flange.**
- 9** Bottom flange will still be exposed: we recommend leaving it this way. If you decide to put a "false shingle" over it, be careful not to nail through skylight flange.

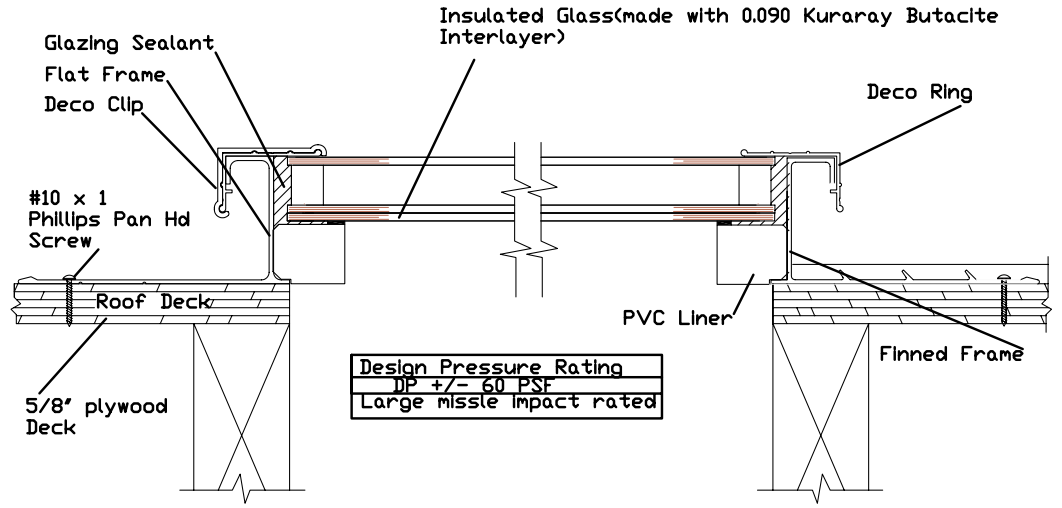
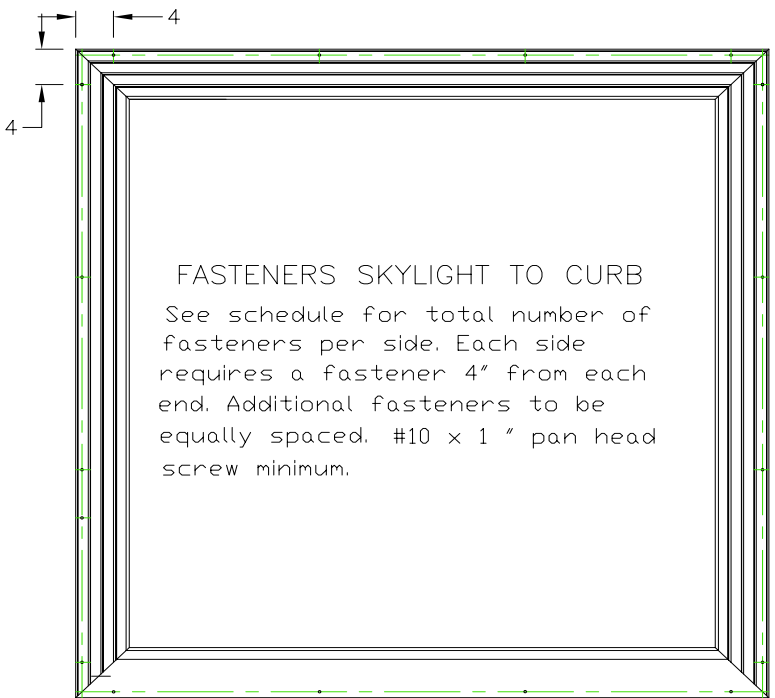
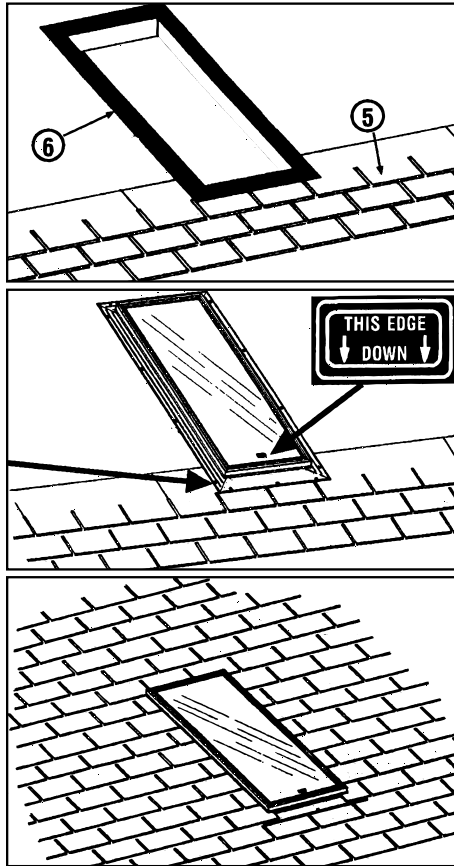

LIGHT TUNNEL INSTALLATION INSTRUCTIONS

For homes with an attic, it is necessary to build a tunnel between skylights and ceiling. The tunnel walls may be straight, or flared for extra light and architectural appeal. It's very easy to increase the tunnel size along the length of the ceiling joists. As long as no roof-supporting members are cut, no special framing is needed. While it is possible to flare the tunnel in all directions, if support members are cut, special framing will be required for structural support. In this case you must consult a qualified building professional to insure proper and safe results.

- 1 After roof and ceiling openings have been framed, measure distance (at each corner of roof opening) between rafter/truss and ceiling joist.
- 2 Using these four measurements, cut 2 x 4 lumber for vertical support members (two per corner).
- 3 In each corner, nail vertical support members into place at right angles to each other.
- 4 Measure, cut, and nail tunnel walls into place. Suggestions for lining tunnel:
 - use drywall, tape corners, and paint white using regular or texture paint. (Texture paint alone will hide and fill untaped joints, but in time, cracks may appear in corners.)
 - use prefinished paneling with molding in corners.
 - line the tunnel with cedar, pine, or a wood to coordinate with your decor.
 - for special effects, try painting the tunnel a striking accent color, or use mirrors or wallpaper on tunnel walls.
- 5 Caulk the slight gap between the tunnel walls and skylight base.
- 6 Finish off tunnel at ceiling with molding, or blend edges into ceiling with texture paint.
- 7 Be sure to wrap the exterior of the tunnel with insulation for energy savings.

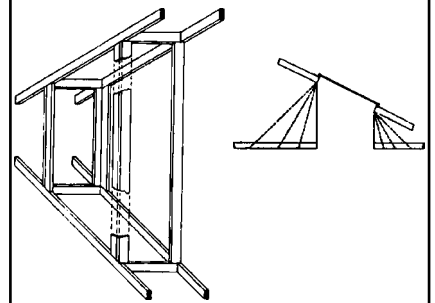

INSULATED GLASS SKYLIGHT LIMITED WARRANTY

Sun-Tek Manufacturing, Inc. ("Sun Tek") 10303 General Drive, Orlando, Florida 32824, (407) 859-2117, warrants this Skylight on the following terms and conditions: **A. Warranty Coverage:** This warranty applies to both the original purchaser and first consumer-owner of a Skylight made by Sun-Tek. **B. Warranty Duration:** This warranty shall remain in effect for a period of twenty (20) years after the date the Skylight is purchased or the date the Skylight is delivered to the first consumer-owner, whichever is later. During the first ten (10) years of this warranty period, Sun-Tek Industries covers 100 percent of all material cost for the entire unit. After 10 years following the initiation of this warranty, Sun-Tek Industries will cover a pro-rated portion and issue a credit as follows:

Years	Coverage
11 to 13	75 percent
14 to 16	50 percent
17 to 20	25 percent

This 20-year limited warranty applies to glass series skylights only for skylights manufactured after January 1, 1998. For products manufactured before January 1, 1998, the warranty period is 10 years. **C. Warranty Application:** This warranty applies only to the materials and fabrication of the Skylight and does not apply to any defect or damage caused by improper use, improper installation, improper care or accident. Glass breakage is not covered. **D. Performance by Sun-Tek:** During the warranty period, Sun-Tek will provide free of charge an equivalent new skylight (or component thereof) for one found to be defective in material or workmanship. Shipping costs of such replacements are not the responsibility of Sun-Tek. Sun-Tek will not be responsible for any costs of removal or re-installation. Condensation or damaged caused by condensation is not covered under this warranty. **E. Validation Procedure:** To obtain performance under this warranty, the purchaser must: (1) On installed skylights, contact Sun-Tek for instructions before removing skylight. Removal of skylight from roof before inspection will void warranty. (2) Notify Sun-Tek in writing of any claim within thirty (30) days after the defect is discovered; and (3) Sun-Tek or its authorized agents must examine high quality installed photographs of the subject skylight and determine to its satisfaction whether the defect is covered by this warranty; and (4) Present a copy of the receipt as proof of purchase. **F. Implied Warranties:** IMPLIED WARRANTIES, INCLUDING BUT NOT LIMITED TO IMPLIED WARRANTIES OF MERCHANTABILITY AND FITNESS FOR A PARTICULAR PURPOSE, SHALL NOT EXTEND BEYOND THE DURATION OF THE EXPRESS WARRANTIES PROVIDED HEREIN. Some states do not allow limitations on how long an implied warranty lasts, so the above limitation may not apply to you. **G. Incidental or Consequential Damages.** SUN-TEK SHALL NOT BE LIABLE FOR ANY INCIDENTAL OR CONSEQUENTIAL DAMAGES WHATSOEVER, INCLUDING BUT NOT LIMITED TO LOSS OF TIME OR REVENUE, GASOLINE, TELEPHONE, OR OTHER EXPENSES. Some states do not allow the exclusion or limitation of incidental or consequential damages, so the above limitation or exclusion may not apply to you. **H. Exclusive Warranty:** THIS WARRANTY IS EXCLUSIVE AND IN LIEU OF ALL OTHER WARRANTIES. This warranty gives you specific legal rights. You may have other rights which vary from state to state.